

Arrive Technologies Inc.

EP4848 EVALUATION PLATFORM

EP4848 User's Manual

Version 2.1

Nov 2007



This controlled document is the proprietary of Arrive Technologies Inc..
Any duplication, reproduction, or transmission to unauthorized parties is prohibited.
Copyright © 2007

Table of Contents

Table of Contents	i
1. USER INFORMATION	1
1.1. About this manual.....	1
1.2. Copyright Notice.....	1
1.3. Trademarks.....	1
1.4. Data Protection.....	1
1.5. No Warranty.....	1
1.6. Document History.....	2
1.7. Convention.....	2
1.8. Safe Instructions.....	3
1.9. Caution.....	4
1.10. Packing And Unpacking.....	5
1.10.1. Packing contents.....	5
1.10.2. Unpacking the AT4848 Evaluation Platform.....	5
1.11. Related Document.....	5
1.12. Customer Communication.....	5
2. INTRODUCTION	6
2.1. Features.....	7
2.1.1. External Optical Interface.....	7
2.1.2. External Electrical Interface.....	7
2.1.3. Control Interface.....	7
3. HARDWARE SETUP	9
3.1. Connecting The Cables.....	9
3.1.1. Connectors on the AT4848 Box Front Side.....	9
3.1.2. Connectors on the AT4848 Box Rear Side.....	10
3.2. Power Requirement.....	10
4. SOFTWARE SETUP	11
4.1. EP4848 browser GUI setup.....	11
4.2. AT4848_SDK setup.....	13
4.3. How to run the AT4848_SDK.....	13
5. ASSEMBLY AND DISASSEMBLY	14
5.1. Disassembly.....	14
5.2. Assembly.....	16
6. TROUBLESHOOTING	17
6.1. Problems and Solutions.....	17
6.2. Check EP4848 Physical.....	18
6.2.1. Common setup.....	18
6.2.2. Check SONET/SDH Physical.....	20
6.2.3. Check GbE/FE Physical.....	23
6.2.4. Check PDH Physical.....	24
7. APPENDIX A – RJ11 COM PORT CONNECTION	26
8. APPENDIX A – SYMBOL EXPLANATION	27
9. APPENDIX B – CUSTOMER FORM	28

Table of Figures

Figure 1: EP4848 Block Diagram	6
Figure 2: EP4848 Motherboard Placement	8
Figure 3: EP4848 Front Side Layout	9
Figure 4: EP4848 Back Side Layout.....	10
Figure 5: The EP4848 Box - AT4848 Evaluation Platform	14
Figure 6: Disassemble The 19" Rack Mounting Handles	15
Figure 7: Disassemble The Top Cover	15
Figure 8: Disassemble the Bottom.....	16
Figure 9: Add/Drop Side Loop-Back Connection	20
Figure 10: Add/Drop Side Loop-Back Connection.....	21
Figure 11: EC-1 Loop-Back Connection	21
Figure 12: GbE/FC Physical Testing Connection	23
Figure 13: 10/100 Base-T/TX Physical Testing Connection	23
Figure 14: DS3/E3 Loop-Back Connection.....	25
Figure 15: RJ11 COM Port Connection	26

1. USER INFORMATION

1.1. *About this manual*

This document only contains the basic information and operating concepts for EP4848 Box, which is a AT4848 SoC Evaluation Platform of Arrive Technologies Inc.

The manual is written for the telecommunication technical reader, so some acronyms and abbreviations do not explain in detail.

Detailed instruction and information should be found via the Arrive's Customer Support with the email address: support@atvn.com.vn

1.2. *Copyright Notice*

Copyright © 2006. Arrive Technologies Inc. All rights reserved.

No part or the whole of this manual and the software described herein are reproduced, translated or transmitted in any form without prior written authorization from Arrive Technologies Inc.

The information provided in this manual is subject to change without notice.

Arrive Technologies Inc. reserves the right to alter product designs, layouts or drivers without notification.

All correspondence regarding your EP4848 box should include the product and purchase information. For your convenience, record the following in the space provide below:

Model Number (e.g. EP4848V20): _____

Serial Number (S/N): _____

Note: Model Number and Serial Number appear on the label on the backside of the box.

1.3. *Trademarks*

All trademarks are the property of their respective holders.

1.4. *Data Protection*

Prior to the installation, All data should be backed-up of any drive unit or storage peripheral. Arrive Technologies Inc. will not be responsible for any loss of data resulting from the use, disuse or misuse of either EP4848 box or any other Arrive Technologies Inc. products.

1.5. *No Warranty*

Arrive Technologies Inc. has made all efforts to ensure the accuracy of this manual content. However, it may contain technical inaccuracies, typographical errors or other errors. Arrive Technologies Inc. assumes no liability neither for any inaccuracies found in this publication, nor for direct, indirect, incidental, consequential damages, or otherwise, that may result from such an inaccuracy, including without limitation loss of data or profits.

Arrive Technologies Inc. provides this manual “**as is**”, and does not issue an express or implied warranty of any kinds, including either without limitation implied warranties of merchantability or fitness for a particular purpose.

1.6. Document History

Revision	Date	Description	Main Changes
1.0	Jun 2006	It is used for the Version 1.0 EP4848 Box, which is equipped either the version 1.0 or the version 2.1 EP4848 Daughter Board is plugged on the Version 1.0 EP4848 Mother Board.	Initial Version
2.0	Oct 2006	It is used for the Version 2.0 EP4848 Box, which is equipped the version 3.0 EP4848 Mother Board.	The EP4848 Daughter Board and the EP4848 Mother board is integrated into the Version 3.0 EP4848 Mother Board
2.1	Nov 2007	It is used for version 2.0 of the EP4848 Box, which is equipped with the version 3.0 EP4848 Mother Board.	The information of RS232 port of the box is added to APPENDIX A – RJ11 COM PORT CONNECTION

1.7. Convention

A.....Ampere
 Arrive..... Arrive Technologies Inc.
 ADM..... Add/Drop Multiplexer
 EoS..... Ethernet over SONET/SDH
 MSPP..... Multi-Services Provisioning Platform
 PoS..... PDH over SONET/SDH
 SFP..... Small Form-Factor Pluggable
 SoC..... System-on-Chip
 MSA..... Multi-Source Agreement

1.8. Safe Instructions

Follow the following safe instructions below step-by-step before you unpack the EP4848 box.

1. Always read the User's Manual carefully; ensure that the version of EP4848 User's Manual is appropriate to the version of EP4848 box. And, Keep this User's Manual for future reference.
2. Keep the equipment away from humidity.
3. Lay the equipment on a secure, reliable, flat surface before setting it up.
4. The openings on the enclosure are for air convection hence protects the equipment from overheating.
5. Place the power cord in such a way that people cannot step on it. Do not place anything over the power cord.
6. Make sure the voltage of the power source and adjust properly 48 VDC @ 2 A (Max. 60 VDC; Min. 40 VDC) before connecting the equipment to the power inlet.
7. If the product is not used for a long period of time remove the product power supply from the mains socket.
8. Always unplug the power cord or power-off before inserting any add-on cards or modules.
9. Never pour any liquid into the opening. Liquid can cause damage or electrical shock.
10. Do not leave this equipment in an environment unconditioned; in storing temperature above 60⁰C; it may damage the equipment.
11. Before cleaning, disconnect the product from DC power.
12. All cautions and warnings on the equipment should be noted.

1.9. Caution

- This product is designed for indoor use only.
- This product must be installed, operated and maintained only by qualified technicians.
- The EP4848 must be operation in the hand with care.
- To prevent possible electrical shock when installing the product, do the following:
 - Make sure that the product power supply is disconnected before installing signal cables.
 - Any peripheral device the product might connect to must be connected to properly wired receptacles, and appropriate connectors.
- Do not supply power until all connections are made in accordance with requirements specified in local electrical section. Protect this equipment with a breaker sufficiently reacted to interrupt power at 48 VDC at 2 A. Only use component and crimping tools approved by agencies or certifying bodies recognized in your country or region. Make sure that the power supply uses at appropriate voltage level:
 - Nominal Differential Input Voltage: 48 VDC @ 1 A in typical
 - Maximum Differential Input Voltage: 60 VDC
 - Minimum Differential Input Voltage: 40 VDC
 - Maximum Supply Current: 1.7 A
- Assemble the cable with fully carefulness.
- Invisible laser radiation is emitted form the optical instrument connectors. Do not view directly with optical instruments. Follow all the safety instruction of the usage optical transceivers, which are installed into the EP4848 box.
- Be careful when working with optical fibers. Fiber cause painful injury if they penetrate the skin.
- If one of the following situations occurs, be sure to get the product checked by a qualified service technician:
 - The product's power supply is overheated, damaged, broken, causes smoke or shortens the mains power socket.
 - Liquid penetrates the product case.
 - The product is exposed to excessive moisture.
 - The product does not work well or you cannot get it to work according to the user's manual.
 - The product has been dropped or mechanically damaged.
 - The product has obvious signs of breakage or internal loose parts.
- Only open the box and attempt to replace or fix any internal part after discussing with the Arrive Technologies Inc. carefully.

1.10. Packing And Unpacking

1.10.1. Packing contents

The AT4848 Evaluation Platform is typically shipped in either a case or cotton box, containing the following items:

- An AT4848 Evaluation Platform.
- A Computer-On-Board DIMM-PC/520-IE.
- Product Documentation (User Manual, User Guide, Chip Browser Manual, etc.)
- An EP4848 Compact Disk, including
 - User's Manual
 - User's Guide
 - Chip Browser software package
 - Chip Browser manual
 - Installation guides
 - Physical Checking Package

1.10.2. Unpacking the AT4848 Evaluation Platform

To unpack your AT4848 Evaluation Platform, open the case carefully, remove the components, and keep the packing materials in case you need to repack the device.

1. First, open the case and remove the product documentation.
2. Lift up the EP4848 box out of the case.

1.11. Related Document

The following documents contain information that you may find helpful as you read this manual:

1. AT4848 Short form Data Sheet
2. AT4848 Long form Data Sheet
3. AT4848 Evaluation Platform Data Sheet
4. EP4848 User Guide
5. EP4848 Software Documents

You can download them at [Arrive Download Center](#) or contact with [the Arrive's Customer Support](#) for further information.

1.12. Customer Communication

Your comments on our products and manual are welcomed by Arrive Technologies Inc.. We are also interested in the applications, in which you develop with our products; and we want to co-operate in your design for helping if you have any problems with the applications. To make it easy, you please complete the form, which are in the [APPENDIX B](#), Customer Communication Form, at the end of this manual, then email to us at the following email address: sales@arrivetechologies.com

2. INTRODUCTION

The EP4848 is the evaluation platform of AT4848 SoC developed by Arrive Technologies Inc.. It is an evaluation and demonstration platform for the AT4848 and its surrounding devices. It can be used to evaluate the performance of the AT4848 using on-board test capabilities or external SONET/SDH, Next-Gen SONET/SDH, PDH and Ethernet test equipment. The EP4848 can also be used to interface to an existing product or network for interoperability. The EP4848 can be used simply to provide pre-configured or dynamically variable channel allocation demonstrations of the capability of the AT4848.

The box is implemented as a full STS-48/STM-16 or STS-12/STM-4 micro-MSP. The Evaluation and Testing can be controlled via a 10/100BT Ethernet port connected to either a PC or a LAN. EP4848 is equipped a standard RS-232 debugging port.

In the inside of the EP4848 Box, it supports internal interface connectors, which are expansion buses of AT4848 SoC. The mechanical mounting holes are also provided for the testing daughter boards installation. Figure 1 shows a block diagram of the EP4848 box.

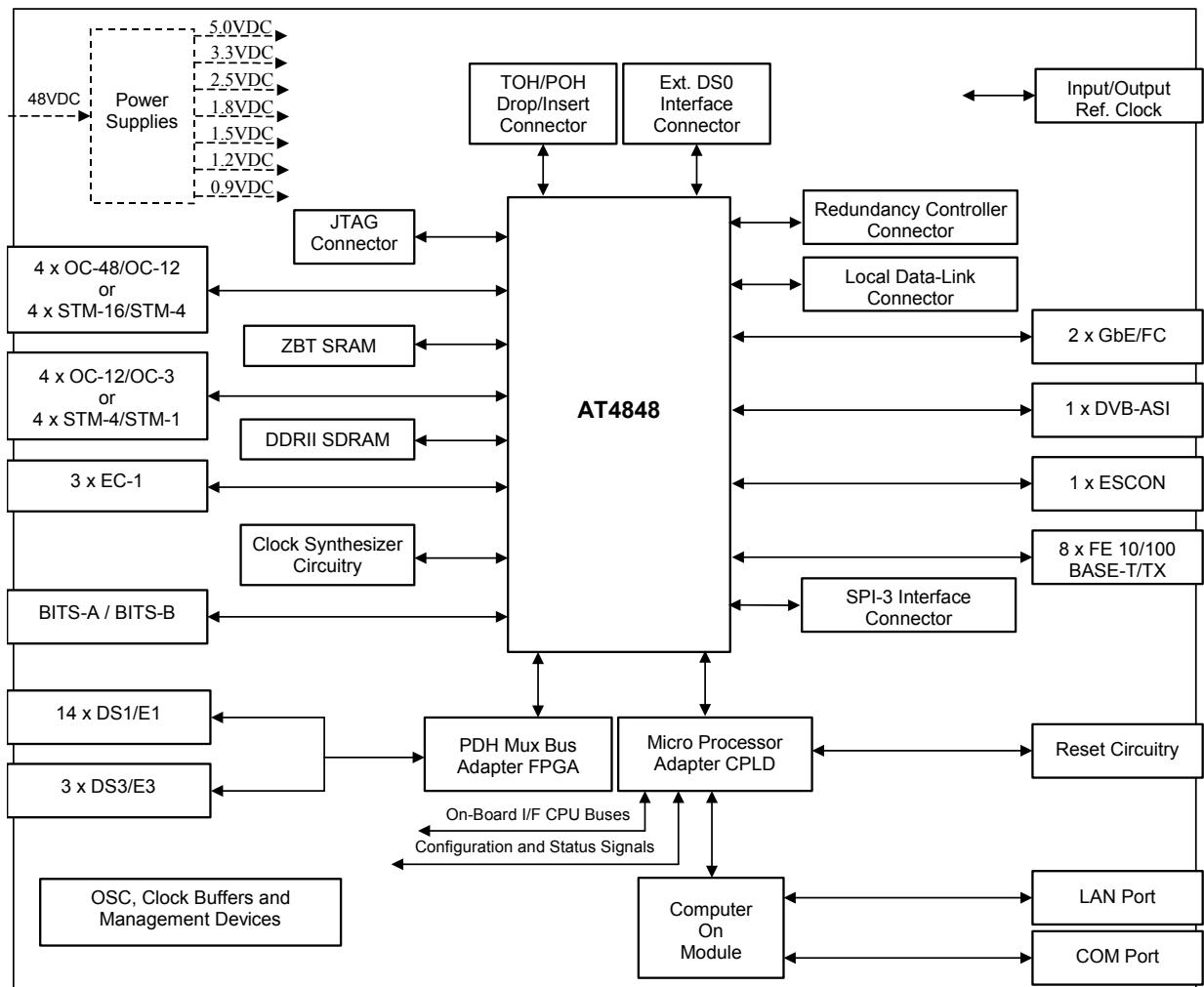

Figure 1: EP4848 Block Diagram

2.1. Features

EP4848 is a compact, flexible, robust design implementation of a complete demonstrating solution for wide variety of application, such as: MSPP, ADM, PoS, EoS, etc..

It is either a standalone box or 19" rack mountable box that allows operation and interoperability testing through the AT4848 interfaces.

2.1.1. External Optical Interface

- Quad configurable either STS-48/STM-16 or STS-12/STM-4 interfaces for SONET/SDH point-to-point, linear network connections.
- Quad individually configurable either STS-12/STM-4 or STS-3/STM-1 interfaces for SONET/SDH adding/dropping services.
- Dual gigabit data interface for Ethernet or Fiber Channel over next-gen SONET/SDH through either GFP-T mapping for GbE/FC or Ethernet MAC function for GbE transport supported with combined VLAN/MPLS/RPR technologies.

Note: All multi-rate optical transceivers are small form-factor pluggable (SFP) optical modules. By using a SFP optical module, it is flexible for selection in optical wavelengths, working distances, optical fiber modes, as well as optical connector type.

2.1.2. External Electrical Interface

- Triple EC-1 port for evaluating flexible SONET/SDH mux function of the AT4848.
- Single DVB-ASI port for DVB over next-gen SONET/SDH via GFP-T mapping.
- Single ESCON port for enterprise services over next-gen SONET/SDH via GFP-T mapping.
- Octal Fast Ethernet interface for Ethernet over next-gen SONET/SDH via Ethernet MAC.
- Fourteen DS1/E1 and Triple DS3/E3 interfaces are provided with respectively movable provisioning across total capacities of 336 and 12 streams of these PDH services.
- Dual E1/DS1 Framed/Un-Framed Building Integrated Timing Supplies (BITS) clock A and clock B for Primary Reference Clock (PRC).
- Single Input Reference Clock
- Single Output Reference Clock

2.1.3. Control Interface

- RJ-45 10/100 BaseT/Tx LAN Port.
- RJ-11 COM Port
- Hardware Reset Button
- Software Reset Button
- LEDs Status Indicator
- 48VDC Power Supply Inlet

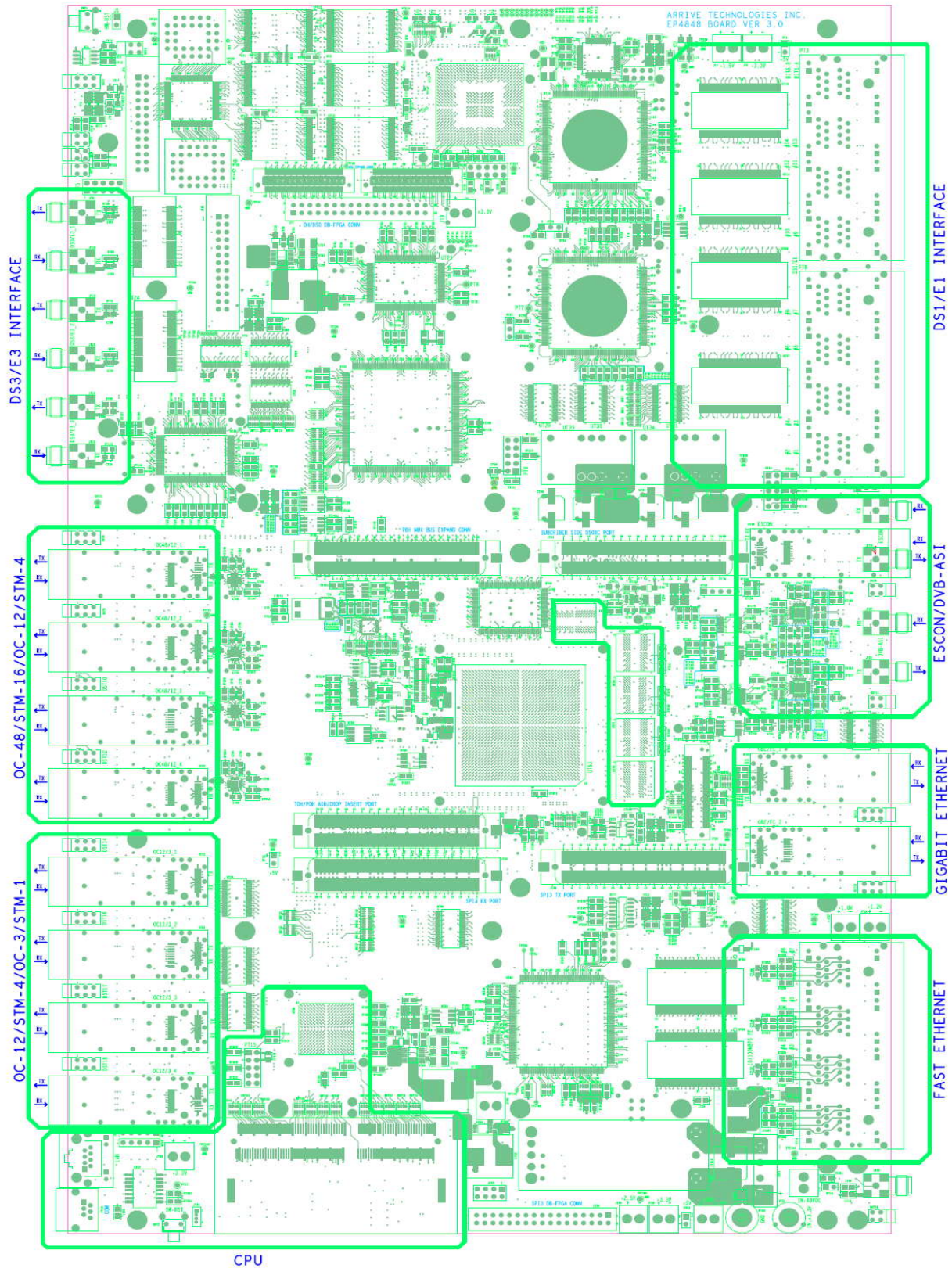

Figure 2: EP4848 Motherboard Placement

3. HARDWARE SETUP

3.1. Connecting The Cables

3.1.1. Connectors on the AT4848 Box Front Side

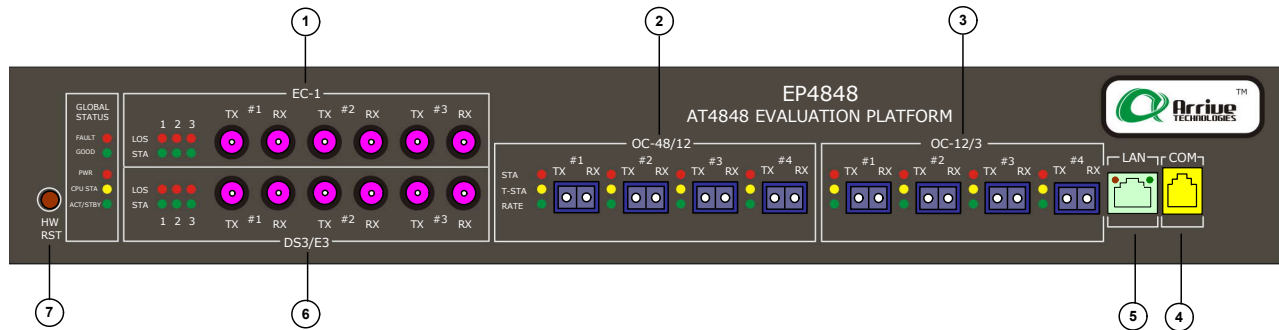

Figure 3: EP4848 Front Side Layout

Where,

1. Triple EC-1/STS-0 ports – 50Ω SMA type.
2. Quad Optical either OC-48/STM-16 or OC-12/STM-4 ports – MSA SFP Optical Transceiver.
3. Quad Optical either OC-12/STM-4 or OC-3/STM-1 ports – MSA SFP Optical Transceiver.
4. Single serial port – RJ-11 connector type.
5. Single 10/100 Mbit LAN Port – RJ-45 connector type.
6. Triple DS3/E3 ports – 50Ω SMA type.
7. Hardware Reset Button.

3.1.2. Connectors on the AT4848 Box Rear Side

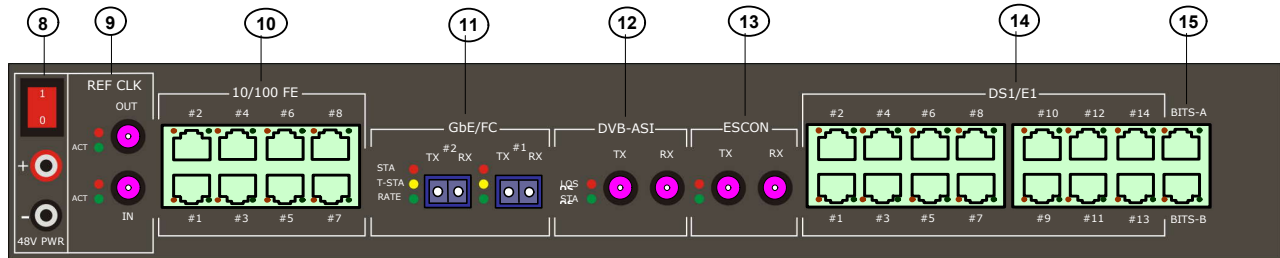

Figure 4: EP4848 Back Side Layout

Where:

8. 48 VDC Power Supply Inlets, and Power Button.
9. Input / Output Reference Clock – 50Ω SMA Connectors
10. Octal 10 /100BASE-Tx Ethernet ports – RJ-45 connector type
11. Dual Optical GbE/FC ports – MSA SFP Optical Transceiver
12. Single DVB-ASI port – 50Ω SMA type
13. Single ESCON port – 50Ω SMA type
14. Fourteen T1/E1 ports – RJ-45 connector type
15. BITS-A port / BITS-B – RJ-45 connector type

3.2. Power Requirement

- Single Power Input: Nor. 48VDC @ 2A (Max. 60VDC; Min. 40VDC)

4. SOFTWARE SETUP

4.1. EP4848 browser GUI setup

Step 1. Run file EP48BrSetup.exe

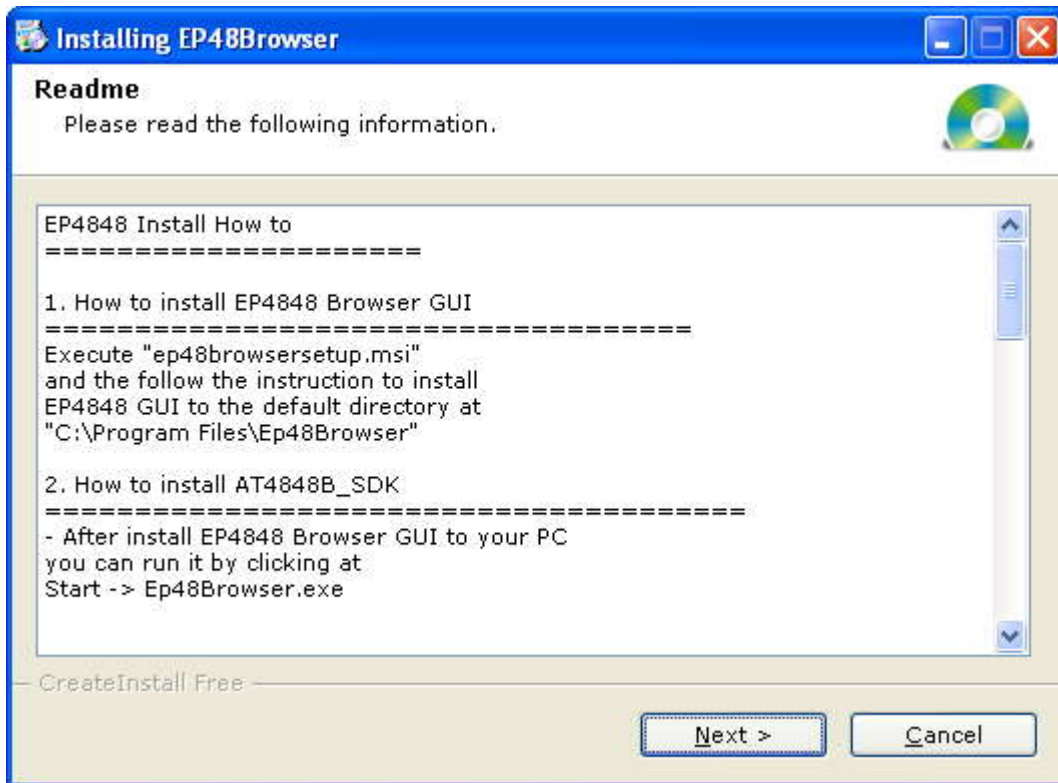

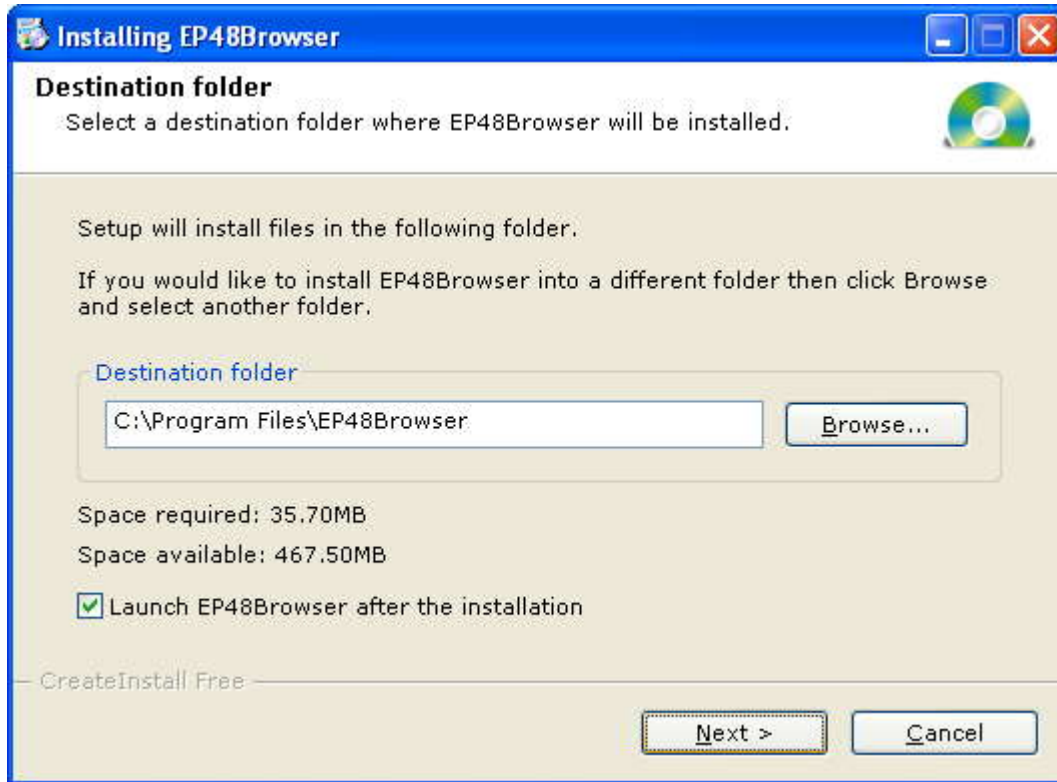
Step 2. Click **Next**

Note: You can use the default directory or Click to “Browse...” to select a different location

Step 3. Continue to click **Next** to install.**Step 4.** Click **Next** to finish the installation.

4.2. AT4848_SDK setup

The size of the at4848_sdk.bin folder is 9820K. If the flash memory of the box has not enough space to store this file, operators should use NFS to mount the at4848_sdk.bin to the EP4848 Box.

After the EP4848 Browser GUI is installed into a PC, run Start\Ep48Browser.exe. Follow the steps below to activate a connection between the EP4848 Browser GUI and the EP4848 box.

Step 1. Click the button "FTP" on the toolbar of the EP4848 Browser GUI in order to activate the FTP client

Step 2. Provide the information of the address, port number of the box and account to log into the box

For example:

- Address: 172.33.35.1
- Port: 21
- User: use
- Password: Leave blank

Step 3. Copy Agent code to the box. In the left-hand panel of the GUI, select Agent code via C:\Program Files\EP48Browser\Agent. Then, right click to the at4848_sdk.bin directory and select "Upload" to copy the Agent code to the "/home/user" directory of the EP4848 box

Another way to copy Agent code to the box is as follows:

- Click File\Connect menu on the EP4848 Browser GUI
- When the connect form appears, click the Copy Agent Source button. The program will automatically copy the at4848_sdk.bin directory to the EP4848 Box at the directory "/home/user".

4.3. How to run the AT4848_SDK

Follow the steps below to run the AT4848_SDK

Step 1. Run the EP4848 Browser

Step 2. Use the Telnet client program to connect to the EP4848 box. The account is as follows

- Username: user
- Password: <Press Enter here>

Step 3. When the login is successful, type the following commands

- cd /home/user/at4848_sdk.bin
- chmod 777 ./*

Step 4. Then, type the command below to run the SDK in the box

- at4848 -f -d -g 5678 -D

After all of the steps above are done, the EP4848 Browser GUI is ready to connect to the box and use all the functions it supports.

5. ASSEMBLY AND DISASSEMBLY

Do following step to:

- Disassembly EP4848 Box to Stand-alone Board.
- Assembly Stand-alone board to EP4848 Box.

5.1. *Disassembly*

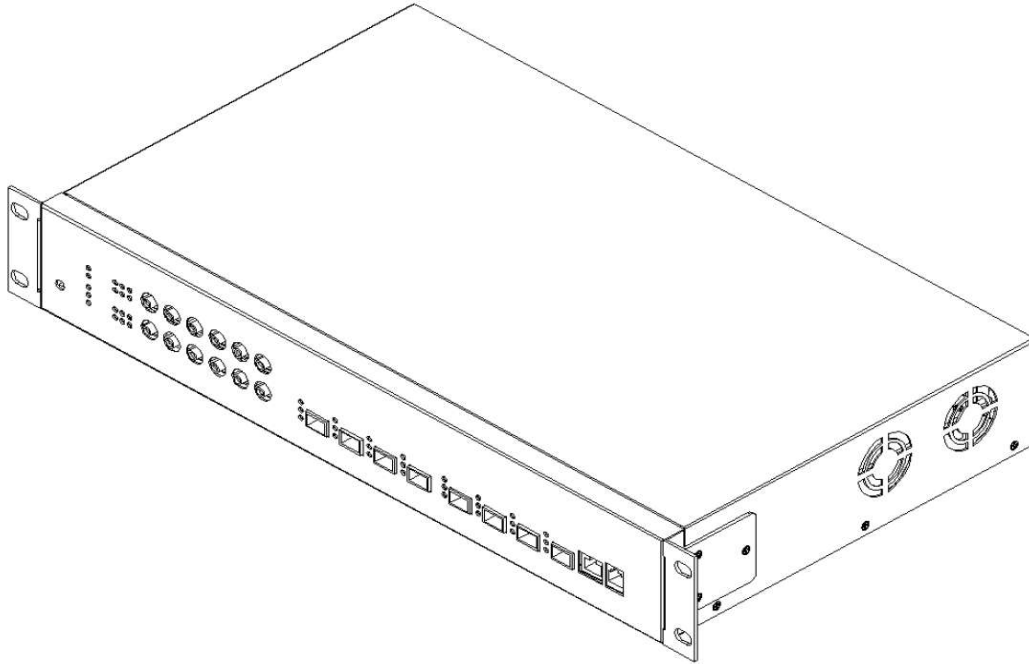

Figure 5: The EP4848 Box - AT4848 Evaluation Platform

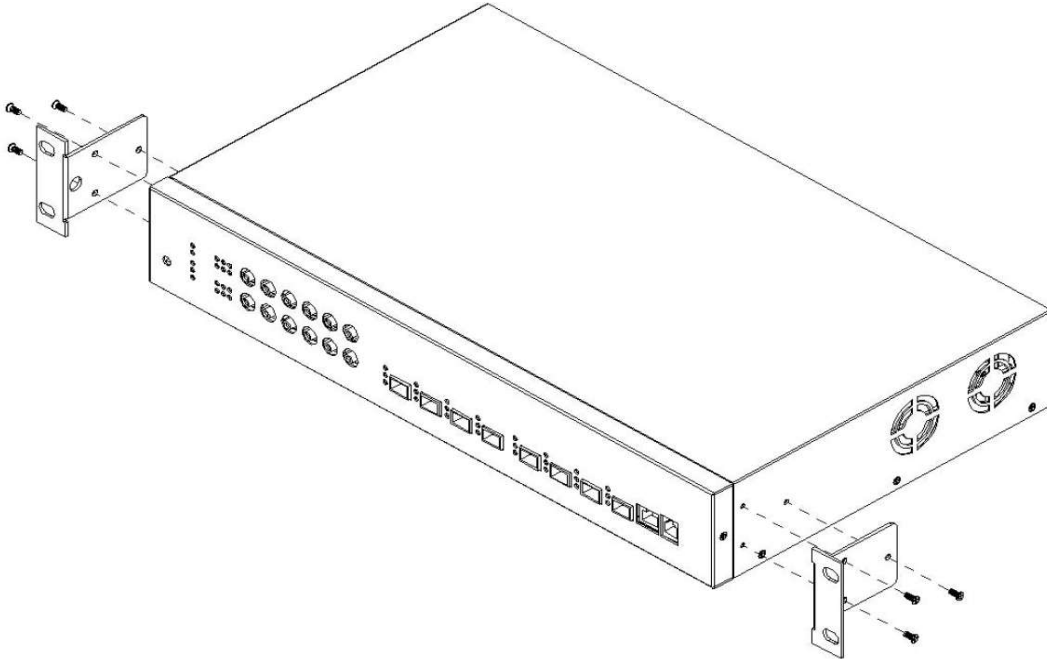

Figure 6: Disassemble The 19" Rack Mounting Handles

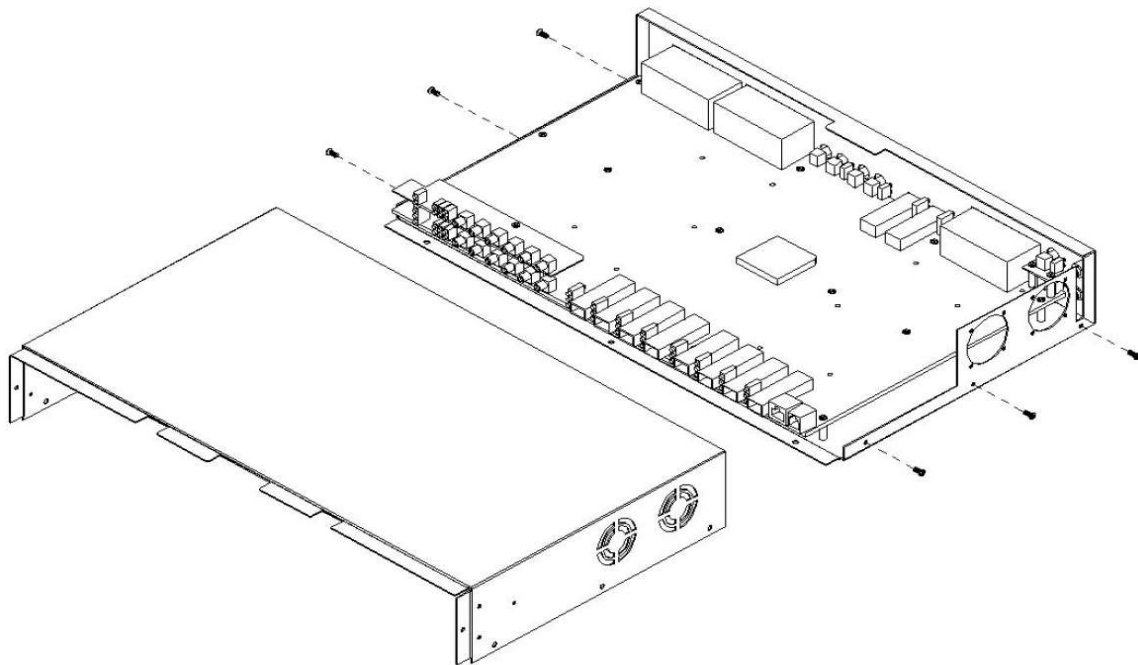

Figure 7: Disassemble The Top Cover

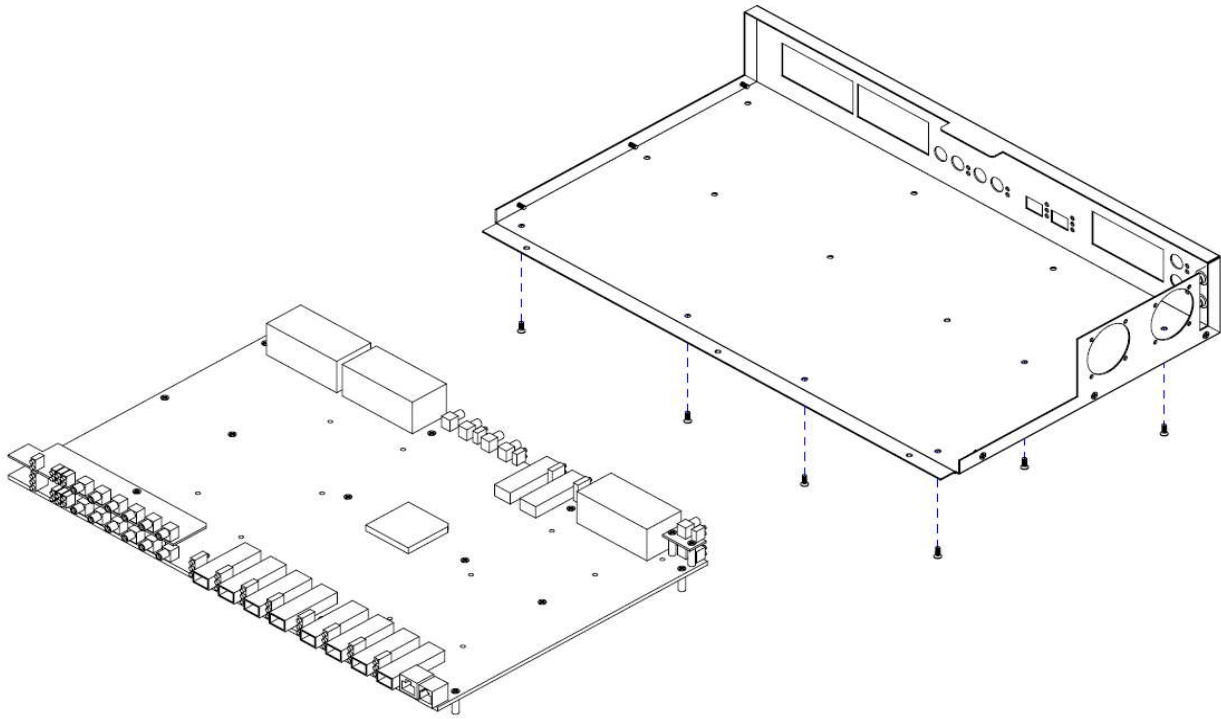

Figure 8: Disassemble the Bottom

5.2. Assembly

To assemble the stand-alone board to EP4848 box, it performs in reverse order.

6. TROUBLESHOOTING

6.1. Problems and Solutions

The following section describes common difficulties that may arise during the use of EP4848 Box and provides simple solutions.

If you still encounter problems, which you cannot resolve, please turn to Arrive Technologies Inc. for assistance.

Problem	Solution
Power Connection	
<ul style="list-style-type: none"> ■ EP4848 box does not start (power LED is dark) 	<ul style="list-style-type: none"> ■ Ensure that power cord is plugged in. ■ Check chassis power connection. ■ Check the power button; ensure the power button is "ON". ■ Ensure that the primary power source has not been inadvertently turned off and that no fuses have blown at the power. ■ Ensure the current applied voltage is in the recommendation value by using voltage Multi-meter.
LAN Connection	
<ul style="list-style-type: none"> ■ Disconnect your PC to EP4848 Box 	<ul style="list-style-type: none"> ■ Ensure that the connection between the RJ-45 connector of EP4848 box and the RJ-45 of either your PC or LAN port is implemented. ■ Ensure that Computer-On-Module DIMM-PC/520-IE is plugged into the SO-DIMM socket on EP4848 board. ■ Ensure the Ethernet connector is attached between EP4848 platform and DIMM-PC/520-IE ■ Observe indicator LEDS at RJ-45 port on the EP4848 Box. Link status LED is green when connection is ready. The LNLED will flicker orange when there is activity on the line. If LEDs are light but you can't telnet DIMM-PC, please wait for few seconds and telnet again. If all LEDs are dark, the problem may be with DIMM-PC/520-IE. In this case, If you have another DIMM-PC/520-IE for back-up purpose, you replace the back-up DIMM-PC/520-IE carefully. If the problem can't fix, you should contact Arrive Technologies Inc. for additional constructions.
No Signal and BER Happen	
<ul style="list-style-type: none"> ■ No signal at the EP4848 input ports such as: LOS, LOF, OOF, etc. ■ BER happens in channels. 	<ul style="list-style-type: none"> ■ Check connection and output status of remote equipment's output ports. ■ If the output port of remote equipment is working, verify proper connector is connected to corresponding input port. The problem is clearly with connector. ■ If connector is OK, you not sure that the problem is with either remote equipment output ports or the EP4848 input ports. You should do following step to identify where is the problem: <ul style="list-style-type: none"> • Do Physical/System loop-back at the remote equipment for checking the output port. • Running the Arrive Technologies Physical Checking Program ... at EP4848 box. If it passes the test, it seemly means that the problem has caused by either outside the EP4848 box or the working configuration. <p>If the problem can't identify, to receive the support, please contact with Arrive Technologies Inc..</p>

Problem	Solution
<ul style="list-style-type: none"> ■ No signal at remote equipment input ports such as: LOS, LOF, OOF, etc. 	<ul style="list-style-type: none"> ■ Check connection and output status of EP4848's output ports.

Note: The section 6.2 depicts how to setup and use Check EP4848 Physical program.

6.2. Check EP4848 Physical

Check EP4848 Physical is a system loop-back program. A package is transmitted through EP4848 TX ports. Then it is received at EP4848 RX ports. Of course, loop-back connection between input ports and output ports is ready. This program check status bits received. If any status bit is error, this program declares a corresponding port is failed. If no, corresponding ports are in the good working condition.

6.2.1. Common setup

Follow the recommended setup procedure below step-by-step to set up the Check EP4848 Physical in the EP4848

- Step 1.** Unplug the power cord or power-off.
- Step 4.** Implement the connection of which you want to check.
- Step 5.** Connect RJ-45 connector between EP4848 Box and either your PC or LAN.
- Step 6.** Connect the product power supply and turn power on.
- Step 7.** Turn on your PC.
- Step 8.** Go to: Control Panel → Network Connection → Local Area Connection Properties → Internet Protocol → Properties.
- Step 9.** Reconfiguration the appropriate IP Address for your PC, for instance:
 - IP Address: **172.33.35.1**
 - Subnet Mask: **255.255.224.0**
- Step 10.** Put EP4848 Compact Disk into your PC's CD-ROM
- Step 11.** Safety, You should backup the data on your computer before doing the next following steps
- Step 12.** Copy the file "ep48.tar.gz" in [Physical Check Package](#) to your work folder (e.g. D:\)

Step 13. Use FTP protocol to copy the file "ep48.tar.gz" in your work folder to DIMM-PC/520-IE on the EP4848 box

- Go to **Start\Run\cmd** to open a Command window
- Type D:\>ftp <IP Address of the EP4848>

Log in the FTP program:

- Type user (in username field)
- Press Enter to leave the password blank (in Password field)
- Type ftp>binary

Copy the file " ep48.tar.gz" to the EP4848:

- Type ftp>put D:\ep48.tar.gz /home/user/ep48.tar.gz

Exit the FTP program:

- Type ftp>bye

Now, you are still in a current Command Window, let follow next steps

Step 14. Use Telnet to activate the Check EP4848 Physical in the EP4848

- Open a Command Window
- Type D:\>telnet <IP Address of the EP4848>

Log in the Telnet program:

- Type user (in username field)
- Press Enter to leave the password blank (in Password field)

Decompress the file "ep48.tar.gz"

- Type [user@AtvnLnx ~]\$ tar -xvf ep48.tar.gz
- Type [user@AtvnLnx ~]\$ cd /home/ep48/bin

Run test program

- Type [user@AtvnLnx ~]\$./at4848_u

This is the common setup, which you have to finish firstly. Then it has to follows next steps of which you want to check specific connector type (e.g. [PDH](#), [SONET/SDH](#), [GbE/FE](#)).

6.2.2. Check SONET/SDH Physical

The test case is to check SONET/SDH including:

- Quad OC-48/OC-12 Optical Interface Ports at Network side.
- Quad OC-12/OC-3 Optical Interface Ports at Add/Drop side.
- Triple EC-1 Electrical Interface Ports.

The connections is depicted by the figures below:

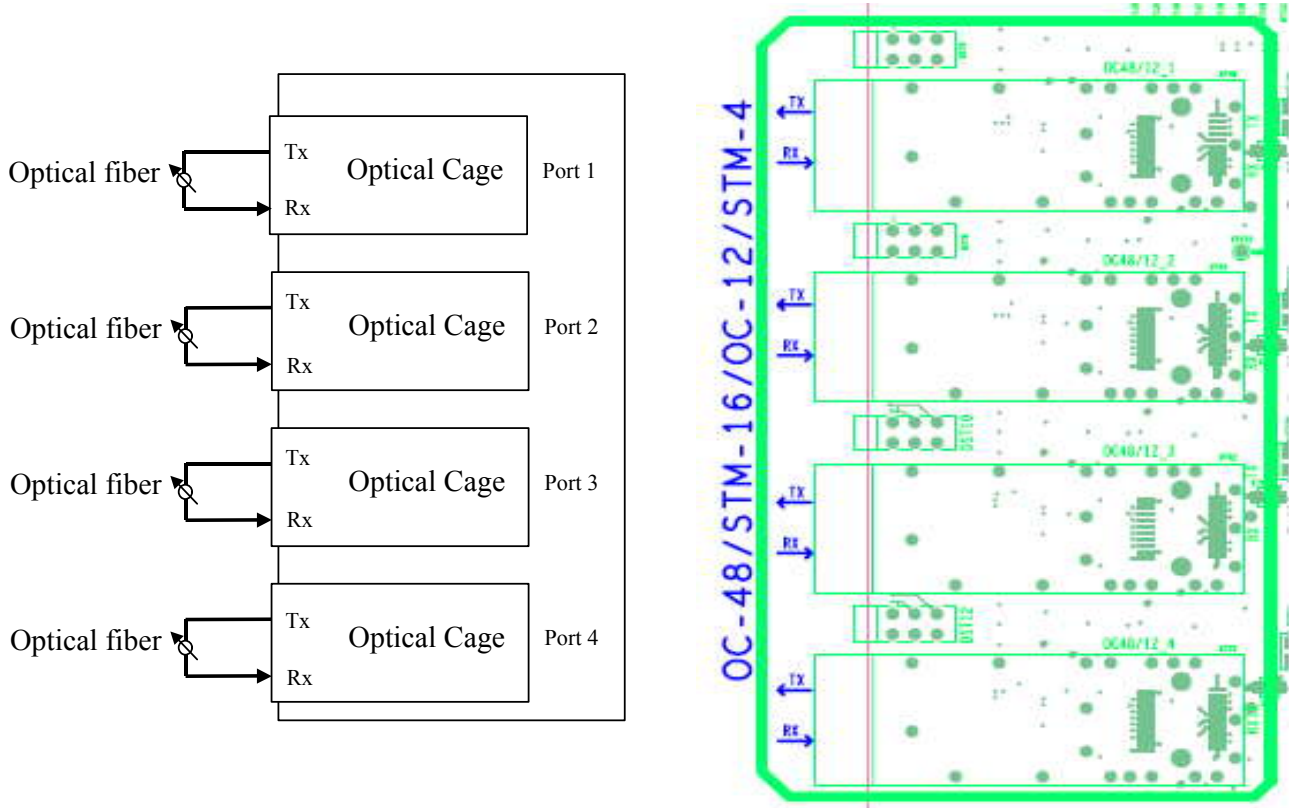

Figure 9: Add/Drop Side Loop-Back Connection

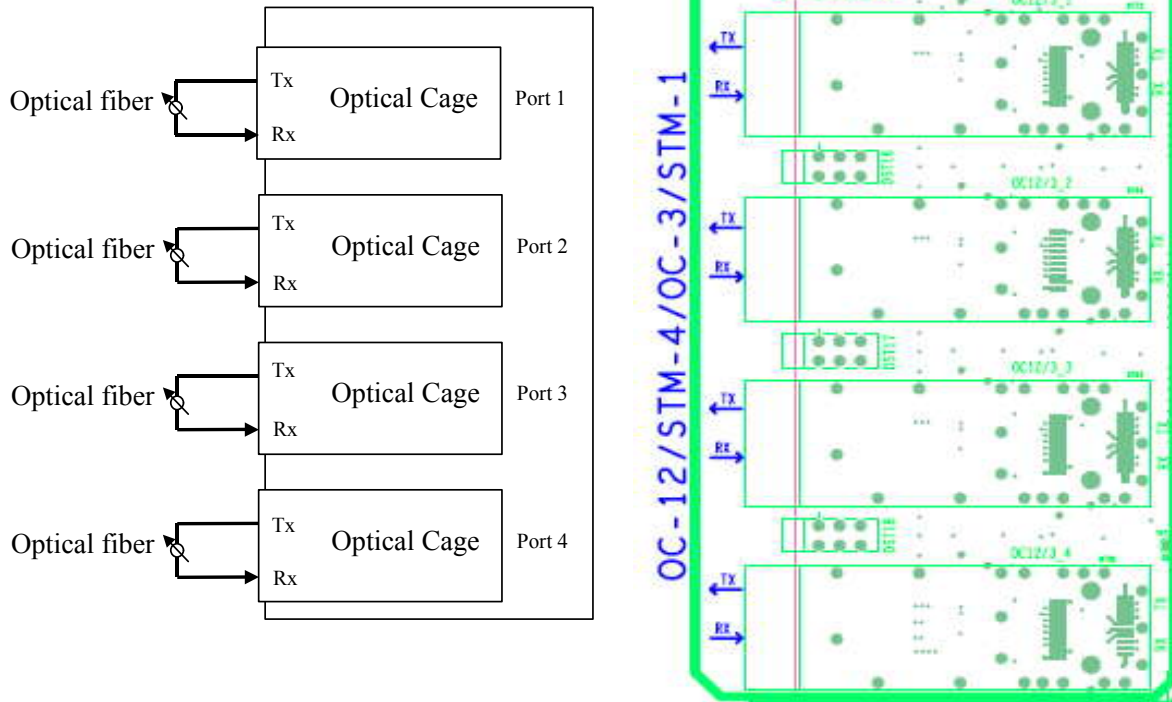

Figure 10: Add/Drop Side Loop-Back Connection

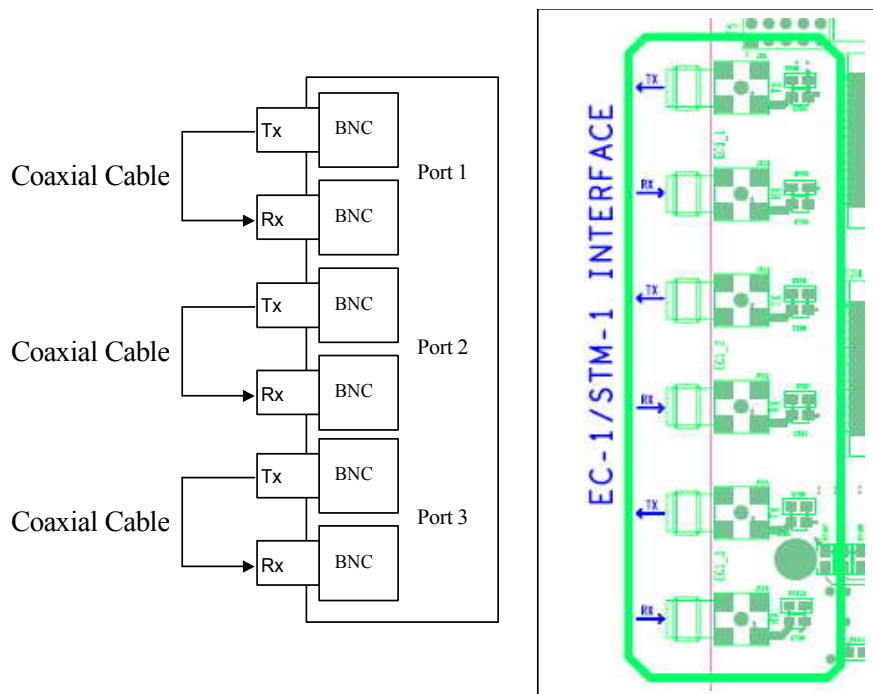

Figure 11: EC-1 Loop-Back Connection

After the common setup, the test case must follow steps below:

- Step 1.** Enable PLL, SONET/SDH ports
 - Type run init
- Step 15.** Stop PDH
 - Type dslu stop
- Step 16.** Run check
 - Type run check
- Step 17.** Exit the check program after test is finished.
 - Type halt

The status of SONET/SDH interface physical ports is OK if there is no error (LOS,LOF,OOB,B1,B2) that is displayed in the Console PC.

The test case is to check all SONET/SDH and PDH. So, when you test a kind of them (e.g. Network), please implement it's connection only and don't care the connection and status of the others.

6.2.3. Check GbE/FE Physical

The test case is to check one either GbE/FC port or Fast Ethernet port. You do same procedure to check the others of FE physical ports.

- Dual GbE/FC Optical Interface Ports.
- Octal 10/100 Base-T/TX Electrical Interface Ports.

The connections is depicted by following figures:

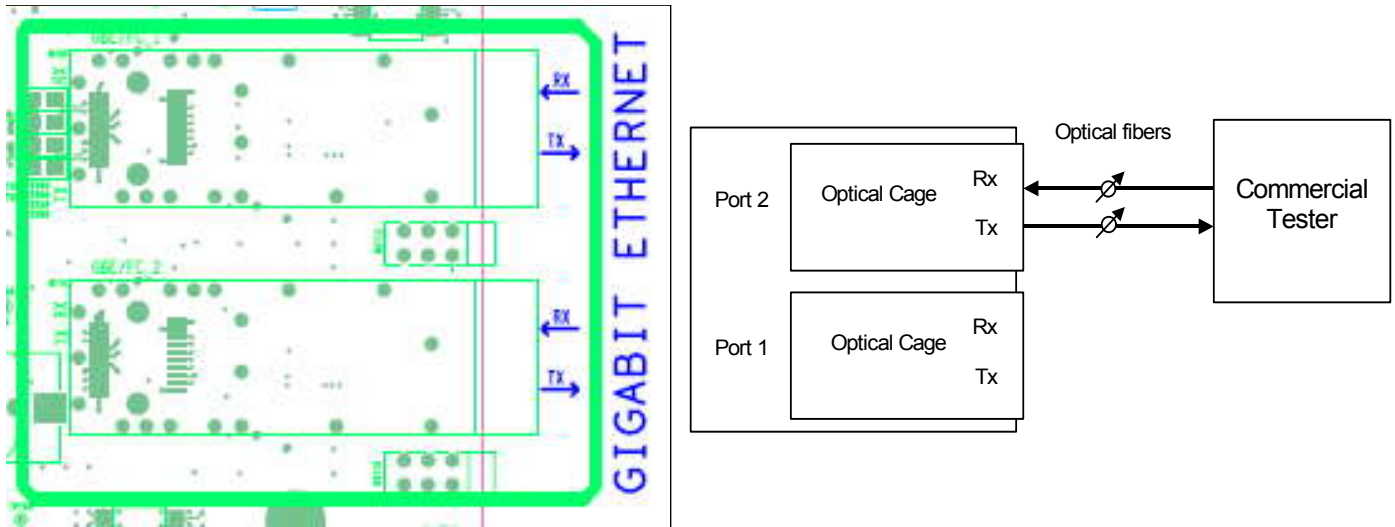

Figure 12: GbE/FC Physical Testing Connection

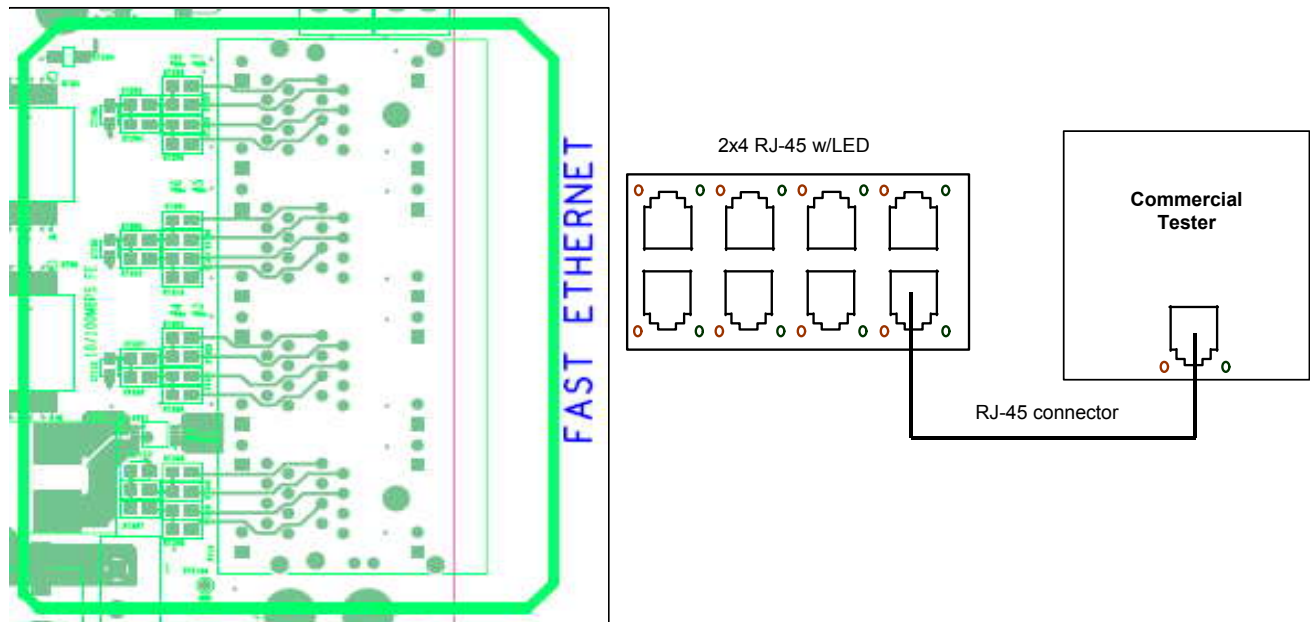

Figure 13: 10/100 Base-T/TX Physical Testing Connection

After the common setup, the test case must follow steps below:

Step 1. Enable all devices by typing the following command

```
- ep alldeven
```

Step 18. Type the command below to run a script file to check Fast Ethernet port

```
- run eth_gefe
```

Step 19. Enable GbE/FE ports (0 →7: FE, 8→9: GbE) via the following command

```
- eth port 0...9 en
```

Step 20. Setup commercial tester properly.

Step 21. Disconnect current port on Ep4848 board, then connect next port

```
- Just unplug connector (RJ-45: FE, Optical fiber: GbE/FC) from the current port on  
EP4848 board and plug it into next port.
```

The status of GE interface physical ports is OK if there is no error that is displayed in the Commercial Tester.

6.2.4. Check PDH Physical

This test case is to check PDH including:

- Triple DS-3/E-3 Electrical Interface Ports.
- Fourteen DS1/E1 Electrical Interface Ports.

The connection is depicted via [Figure 14](#):

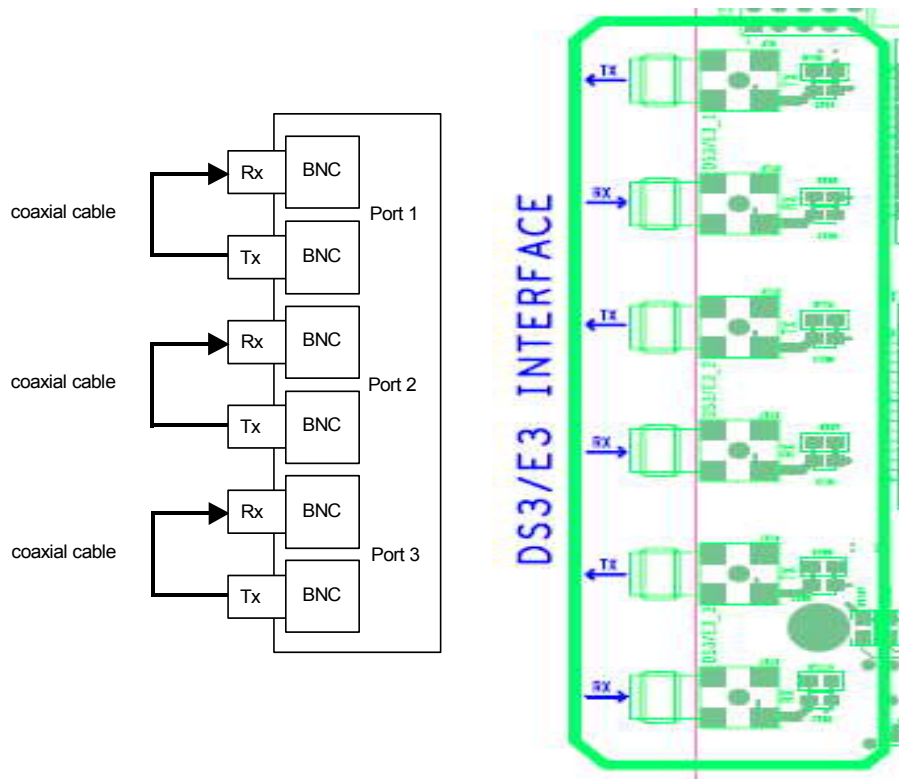

Figure 14: DS3/E3 Loop-Back Connection

The connection for DS1/E1 is not requirement. It is ready by program.

After the common setup is finished, the test case must follow steps below:

Step 1. Enable PLL, PDH ports by typing the following command

```
- run init
```

Step 22. Type the command below to start the check program

```
- run check
```

Step 23. Type the following command to exit the check program after test is finished.

```
- halt
```

The status of PDH interface physical ports is OK if there is no errors such as LOS, LOF and OOF which are displayed in the Console PC.

The test case is to check all SONET/SDH and PDH. So, when you test a kind of them (e.g. DS3), please implement it's connection only and don't care the connection and status of the others.

7. APPENDIX A – RJ11 COM PORT CONNECTION

Figure 15 illustrates the connection between the RJ11 COM port of the EP4848 box and a COM port of a PC

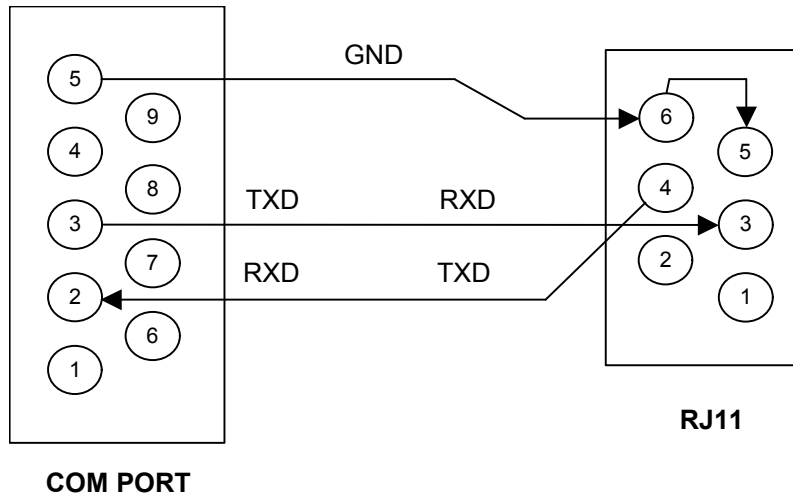

Figure 15: RJ11 COM Port Connection

Engineers/operators must follow the following guidelines on a connection between a PC and the EP4848 box via the RJ11 COM port.

- Step 1.** Use a cable which has 2 interfaces as in [Figure 15](#)
- Step 2.** Plug the RJ11 interface of the cable to the COM port of the EP4848
- Step 3.** Plug the COM PORT interface of the cable to a COM interface of a PC
- Step 4.** Use a program to transfer data through the RS232 interface, for example TERM 95 program
- Step 5.** Configure COM setting in the program:









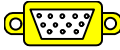
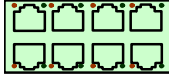

Open Setting Menu, select:

Port: COM 1
Baudrate: 9.600
Databits: 8 BITS
Parity: None
Stopbits: 1 BIT

Then click OK for approving the setting.

- Step 6.** If the connection is Ok, the terminal display login window of the EP4848 box. Use login account: User name: user, Password: (empty password) to log to the box. Now users can operate the box as a Linux PC.

8. APPENDIX A – SYMBOL EXPLANATION

Connectors and functional button	Symbol
SMA connector	
SFP Optical Cage	
VGA port	
2x4 RJ-45 w/LED	
COM port	
USB port	
RJ-45 w/ LED	
DC power	
Signal Red/Green Leds	
Signal Red/Green/Yellow Leds	
Power status	
Reset button	

9. APPENDIX B – CUSTOMER FORM

If you have any problems in the application tests, you please complete the following form, then send to Arrive's Technical Support with following email address: [mailto: support@atvn.com.vn](mailto:support@atvn.com.vn)

Company:		
Name:		
Address:		
Email:	Phone:	Fax:
EP4848 Box Version:	ATVN Linux OS Version:	Software Version:
Testing Configuration:		
Problem Description:		
Error Messages:		
The following steps reproduce the problem:		
Note:		