



AT1250

OC-12/3 Ethernet over PDH/SONET Mapper

Rev. 1.4 – May 2008



Preliminary Short Data Sheet

GENERAL DESCRIPTION

The AT1250 provides a multi-format and multi-rate Ethernet and common legacy data over PDH, PDH mapped to SONET/SDH or direct SONET mapping. On the PDH side, the chip provides a parallel multiplexed PDH bus carrying 12 DS3s or 12 E3s or 336 DS1s or 252 E1s or any mixture of them. A simple FPGA is used to convert parallel DS1/E1/DS3/E3 signals on the PDH bus to the serial signals required for the LIUs for pin count expansion. The 336DS1/252E1s signals can be accessed directly on the PDH bus or be multiplexed to 12 channelized DS3/E3s via 12 embedded M13/E13 engines or mapped to SONET/SDH. The chip supports a quad OC-12/STM-4/OC-3/STM-1 SONET/SDH interface with 1+1 protection, UPSR and mapping of DS1/E1/DS3/E3 to SONET/SDH. On the Ethernet side, the chip provides 8 Fast Ethernet ports via SMII/SS-SMII bus and 2 Gigabit Ethernet ports with on-chip CDRs. It also supports an OIF SPI-3 bus to support external devices such as a Packet Switches, Network Processor to provide extended L2+ or L3 level processing or expansion of the Ethernet ports. The AT1250 supports ATM, GFP-T/F, HDLC, PPP and LAPS encapsulation. A Traffic Aggregation and Management at Layer 2 for VLAN/MPLS with Classifying, Policing, Queuing, Shaping, and Scheduling is provided. It provides direct SONET/SDH mapping, SONET/SDH/PDH virtual concatenation (VCAT) and LCAS with 128 groups in accordance with G.7041, G.8040, G.7042 and G.7043. The AT1250 includes flexible channel assignment for all applicable SDH and SONET mappings. A serial port is provided for ESCON, DVB-ASI or low speed Fiber Channel SAN applications.

KEY FEATURES

- ❑ Eight 10/100Mbps Ethernet ports via SMII/SS-SMII
- ❑ Two 1Gbps Ethernet ports with on-chip CDR
- ❑ One ESCON/DVB-ASI/Low Speed FC (200/270/531Mbps) port with serial clock and data interface
- ❑ 128 Logical ports SPI-3 interface for Ethernet expansion
- ❑ Quad multi-rate OC-12/STM-4/OC-3/STM-1 ports with on-chip CDR
- ❑ 12 DS3/E3s, or 336 DS1s, or 252 E1s or any mixture of them on a multiplexed PDH bus
- ❑ Ethernet MAC controller with flow control including jumbo frame
- ❑ Support 802.3ah Ethernet OAM processing and loopback
- ❑ 128 Hi/Lo-Order/PDH VCAT channels with external memory supported delay compensation and on-the-fly programmable differential delays for each VCAT channel
- ❑ Each VCAT channel supports differential delay with up to 384ms for DS1s, up to 256ms for E1/E3s and up to 217ms for DS3s, up to 256ms of STS/VC/VT/TU
- ❑ LCAS with hitless add/remove and fault isolation
- ❑ GFP-F/T, PPP/HDLC, LAPS and ATM encapsulation
- ❑ Traffic Aggregation and Management at Layer 2 for VLAN/MPLS with Classifying, Policing, Queuing, Shaping, and Scheduling
- ❑ Eliminates an external packet SDRAM for transportation of Ethernet ports over PDH without statistical multiplexing
- ❑ 12 DS3 C-bit Parity and DS3 M13 multiplexing
- ❑ 12 E3 G.832 and E3 G.751 E13 multiplexing
- ❑ 336 DS1 SF/ESF Framers supporting J1 SF/ESF
- ❑ 252 E1 basic frame or CRC-4 multi-frame framers
- ❑ Mapping of 336DS1/252E1 and 12DS2/E3 to SONET/SDH
- ❑ 2x16Mx16 DDR2 SDRAM for VCAT delay compensation (can be eliminated if VCAT is not utilized)
- ❑ 3x32Mx16 DDR2 SDRAM for Data Aggregation buffer (can be eliminated if Data Aggregation is not utilized)
- ❑ 1x512Kx36 ZBT SSRAM for hardware status
- ❑ Provided in an HFC-BGA1296 package
- ❑ Typical power consumption is 5 watts

APPLICATIONS

- ❑ Carrier Ethernet wireless and business aggregation and backhaul systems
- ❑ Customer Premises Data Service aggregation and multiplexers
- ❑ Routers, Switches, Edge Systems, MSPPs and Broadband DLCs
- ❑ NxDS1/E1 carrying packet data from mobile backhaul base stations to transport network
- ❑ NxDS1/E1 over DS3/E3 M13/E13 carrying packet data from mobile backhaul base stations to transport network
- ❑ NxDS3/E3 carrying packet data from Business or Enterprise to transport network

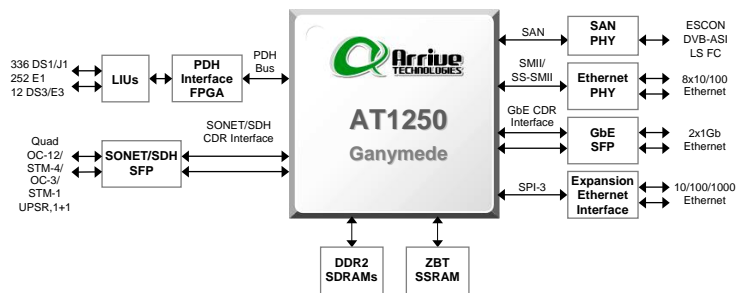

AT1250 BLOCK DIAGRAM

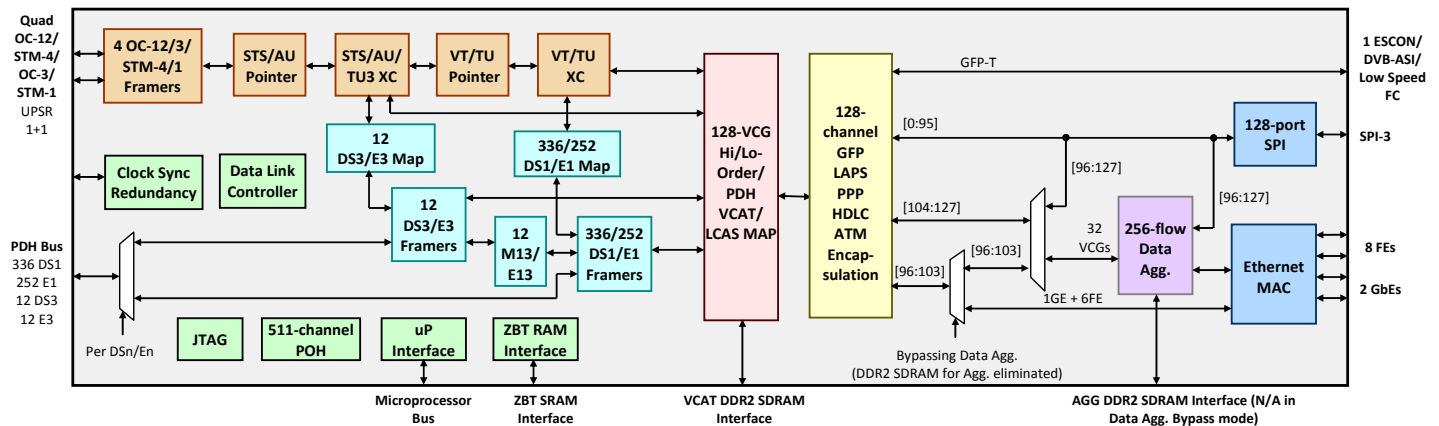



FEATURES SUMMARY

Ethernet MAC

- ❑ Complies with MAC for Gigabit and Fast Ethernet framing, flow control handling and auto-negotiation
- ❑ Support Ethernet OAM processing and loopback in compliant with IEEE 802.3ah
- ❑ IEEE 802.3 flow control protocol over SONET transparently
- ❑ Rate limiting based Rx Ethernet FIFO
- ❑ Jumbo frame support
- ❑ MAC Counters for Ethernet Statistics
- ❑ Optional FCS Insertion at Transmit Ethernet MAC
- ❑ Supports Ethernet OAM extraction and insertion
- ❑ Support EoS/EoPDH/EoPoS with or without Data Aggregation

SPI-3

- ❑ 8-bit/16-bit/32-bit OIF SPI-3 Interface up to 128 physical ports
- ❑ Programmable data segmentation of 64 or 128 bytes providing flexible interface to encapsulation supporting varied data packet protocols
- ❑ SPI-3 to/from Data Aggregation have a LUT which can configure any SPI port to any Aggregation VCG

L2 Aggregation & Management

- ❑ Supports Layer 2 Aggregation with VLAN, VLAN Stacking (QinQ)
- ❑ Supports MPLS pseudowire emulation (PWE)
- ❑ Supports GFP Multiplexing
- ❑ Supports all functions of Aggregation including Classifying, Policing, Queuing, Shaping and Scheduling.
- ❑ Classifying function based on port ID, VLAN ID and priority bits or MPLS via a lookup CAM
- ❑ Policing function based on the MEF10 technical specification from the Metro Ethernet Forum
- ❑ Supports 256 service flows/queues
- ❑ Deficit Weighted Round Robin (DWRR) or Strict Priority Scheduler provided for scheduling
- ❑ Ethernet MAC Class-of-Service (CoS of IEEE 802.1p) and MPLS EXP bits of VC label mapping
- ❑ MPLS label stack with Virtual Connection Label (VCL) and Tunnel Label (TL) in accordance with the IETF drafts

Data Encapsulation

- ❑ ATM, GFP, PPP/HDLC, LAPS simultaneously, full-duplex 128 channels
- ❑ ATM, GFP, PPP/HDLC, LAPS mapping to PDH in compliance with G.8040, X.85/86 and G.804
- ❑ Supports Fiber Channel (FC), ESCON, DVB-ASI over SONET/SDH via GFP-T
- ❑ Complies with ITU-T I432.2 (ATM), ITU-T G.7041 (GFP), RFC-1619/1662/2615 (PPP), ITU-T X.85/86 (LAPS), HDLC mapping standards
- ❑ Cell HEC and packet FCS checker/generator and 1-bit HEC error correction
- ❑ Idle/unassigned cell, aborted sequence detection/generation
- ❑ Cell/packet payload scrambling/de-scrambling
- ❑ Bit stuffing and byte stuffing on PPP and HDLC
- ❑ Supports rate adaptation for LAPS/HDLC/PPP
- ❑ Extraction and insertion header field support
- ❑ Supports frame extraction and Insertion
- ❑ Supports 16 or 32 bit HDLC frame check sequence field (FCS) per channel

Datalink Controller

- ❑ 512 standard HDLC channels
- ❑ DCC bytes from SONET/SDH framers
- ❑ Bit-oriented Message and Facility Data Link from PDH framers
- ❑ Data Link in K3 bytes from Path Overhead (POH) processor
- ❑ Flexible datalink buffer setup and management significantly offloading host processor from real time demands from the large channel count

Redundancy Controller

VCAT & LCAS

- ❑ 336DS1/252E1/12DS3/12E3 of PDH termination, STS-24 of STS/VC termination, and STS-12 VT/TU termination via 128 channels
- ❑ Supports PDH VCAT and LCAS in compliance with G.7043
- ❑ Supports Standard Contiguous, any Random and Virtual Concatenation
- ❑ Complies with Link Capacity Adjustment Scheme (LCAS) as in ITU-T G.7041 with hitless addition/removal and fault isolation
- ❑ TUG-3 SDH Concatenation with both VC-4-Xv and VC-3-Xv support
- ❑ Contiguous and Random Concatenation with Hi-order VC-3-Xc (X=1-12), VC-4-Xc (X=1-4), Lo-order VC-2-Xc (X=1-7), VC-12-Xc (X=1-21) and VC-11-Xc (X=1-28)
- ❑ Virtual Concatenation (VCAT) with Hi-order VC-3-Xv (X=1-24), VC-4-Xv (X=1-8), Lo-order VC-2-Xv (X=1-21), VC-12-Xv (X=1-63) and VC-11-Xv (X=1-64)
- ❑ PDH VCAT levels with Nx1544, Nx2048 (N=1-16), Nx34368, Nx44736 (N=1-8)
- ❑ Data mapping over DS1/J1/E1/DS3/E3 in compliance with G.8040, X.85/86 and G.804
- ❑ Supports Data/Ethernet mapping-over-PDH over SONET/SDH
- ❑ Accommodates a PDH VCAT differential delay of 384ms for DS1s, 256ms for E1/E3s, and 217ms for DS3s, 256ms of STS/VC/VT/TU
- ❑ Low optimized packet latency in VCAT De-skew
- ❑ On-the-fly programmable differential delays for each VCAT channel to permit short loop and long international paths
- ❑ SPI-3 interface has a maximum of 128 VCGs for transporting data over PDH/SONET/SDH

SONET/SDH

- ❑ Built-in 4 OC-12/STM-4/OC-3/STM-1 Framers
- ❑ Full SONET/SDH Section/Line Overhead processing
- ❑ Hardware based APS processing for Linear and UPSR
- ❑ Standard Contiguous and any Random Hi-order and Lo-order pointer processing
- ❑ Full STS/VC and VT/TU Path monitoring/termination through a selectable 511-channel pool
- ❑ Full SONET/SDH Line 10-3 to 10-9 hardware BER detection
- ❑ Selectable 511 STS/VC, VT/TU with 10-3 to 10-9 hardware BER detection

STS/AU/VT/TU Cross Connect

- ❑ 132x132 STS-1/VC-3s Cross-connect
- ❑ 24x24 TU3s Cross-connect
- ❑ 1344x1344 VT-1.5/TU-11s Cross-connect

PDH Features

- ❑ Integrates 336 DS1/J1 framers, 252 E1 framers, 12 DS3/E3 framers
- ❑ Implements bit asynchronous mapping of 336 DS1/J1 to VT1.5/TU11 or 252 E1 to VT2/TU12 or any mixed
- ❑ Supports 12 M13/E13 multiplexers with 12 DS3/E3 framers
- ❑ Supports mapping of VT1.5/VT2/TU11/TU12 and DS3/E3 to SONET/SDH SPE
- ❑ DS1/E1 to DS3/E3 Mux, Asynchronous DS1/E1 to VT/TU Map, Asynchronous DS3/E3 to STS1/VC3 Map with Jitter Attenuation
- ❑ Supports PDH VCAT and LCAS in compliance with G.7043
- ❑ PDH multiplexed bus requires external FPGA for mux/demux and external LIUs with jitter attenuation

System Clock Synthesizer

- ❑ Accepts the multiple of 8KHz input reference clock and monitor clock
- ❑ Accepts an 8KHz or 1.544MHz/2.048MHz input reference clock and an 8KHz or 1.544MHz/2.048MHz input monitored clock
- ❑ Selectable clock reference and clock monitoring from SONET/SDH Line or Hi-order or Lo-order path
- ❑ Supports Free-run, Locked, and Holdover modes of operation
- ❑ Supports working/protection clock synchronization with multi-



AT1250

OC-12/3 Ethernet over PDH/SONET Mapper



Rev. 1.4 – May 2008

Preliminary Short Data Sheet

- 10Mbps redundancy data link
- Active/standby switchover under software control

frame phase accuracy of 6.43ns